

1.

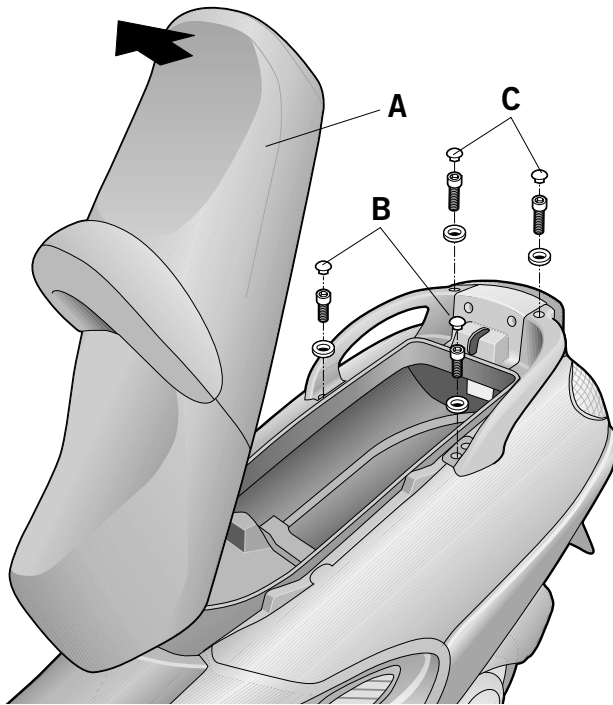

- (E)** Abrir el asiento (A).
Desmontar y desestimar los tapones (B) y (C).
- (GB)** Open the seat (A).
Loosen and remove the covers (B) and (C).
- (F)** Ouvrir la selle (A).
Démonter et enlever les bouchons (B) et (C).
- (D)** Den Sitz (A) öffnen.
Die Stöpsel (B) und (C) ausbauen und entfernen.
- (I)** Aprire il sedile (A).
Smontare e togliere i tappi (B) e (C).

2.

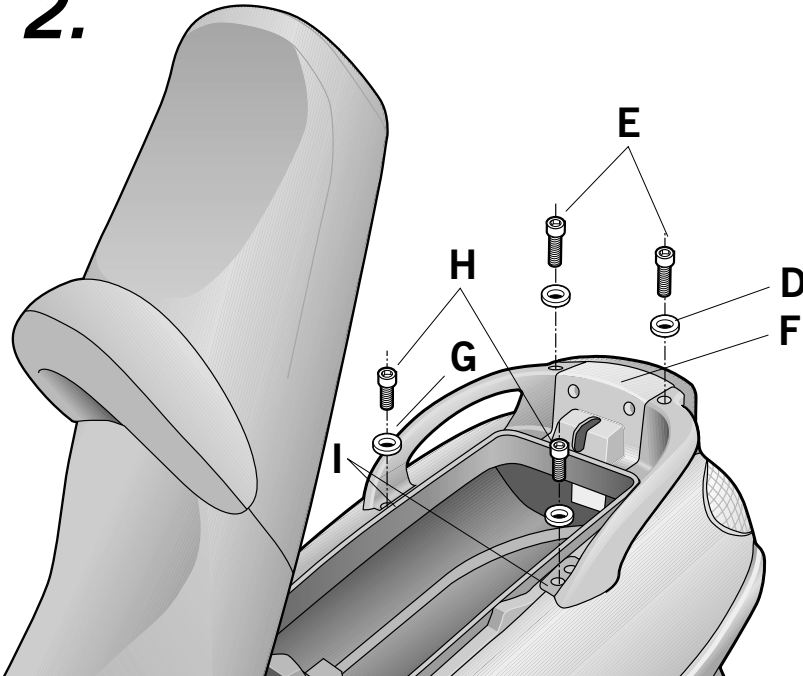

- (E)** Desmontar y desestimar las arandelas (D) y los tornillos (E) en zona (F), y las arandelas (G) y los tornillos (H) en zona (I).
- (GB)** Loosen and remove the washers (D) and the screws (E) in the zone (F), and the washers (G) and the screws (H) in the zone (I).
- (F)** Démonter et enlever les rondelles (D) et les vis (E) en zone (F), et les rondelles (G) et les vis (H) en zone (I).
- (D)** Die Scheiben (D) und Schrauben (E) in Zone (F), und die Scheiben (G) und Schrauben (H) in Zone (I) abbauen und entfernen.
- (I)** Smontare e togliere le rondelle (D) e le viti (E) nella zona (F), e le rondelle (G) e le viti (H) nella zona (I).

3.

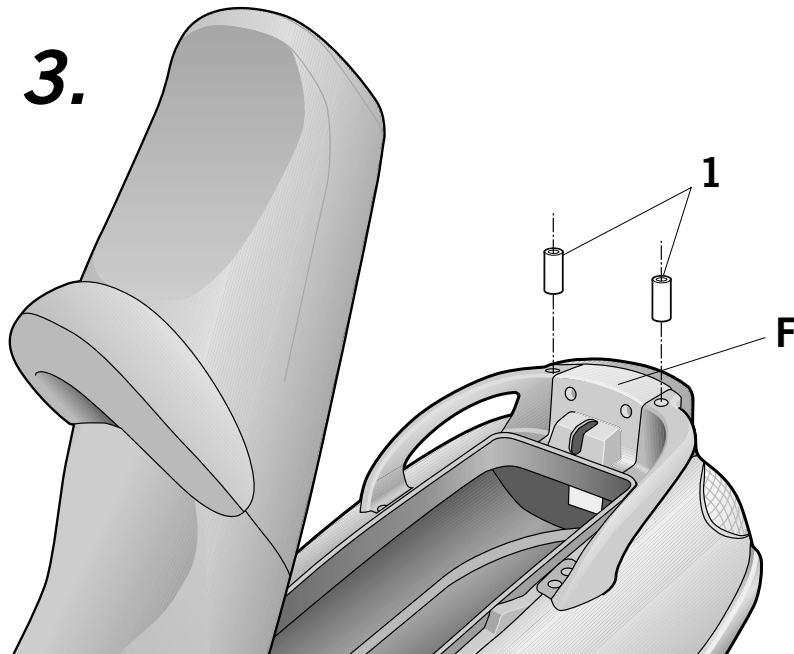

- (E)** Colocar los distanciadores (1) en zona (F).
- (GB)** Place the spacers (1) in the zone (F).
- (F)** Placer les entretoises (1) en zone (F).
- (D)** Die Abstandshalter (1) in Zone (F) anbringen.
- (I)** Collocare i distanziatori (1) nella zona (F).

4.

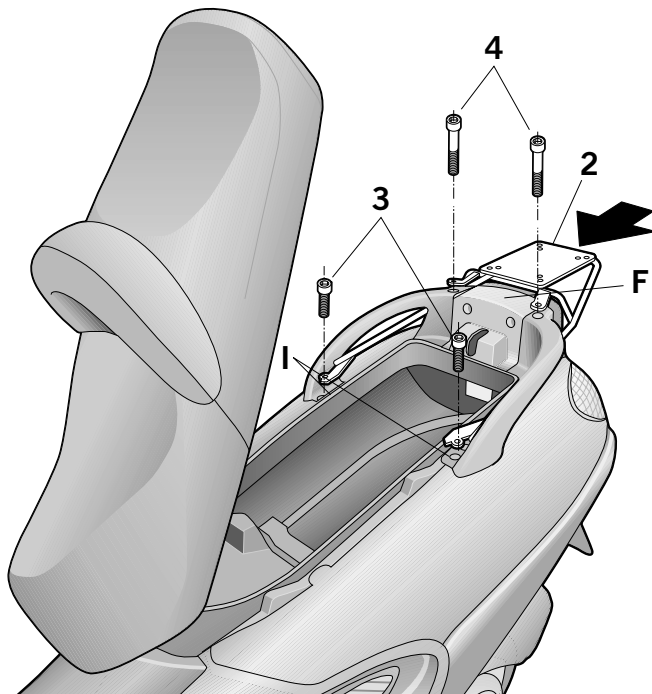

- (E)** Montar el KIT TOP (2) mediante los tornillos (3) en zona (I) y los tornillos (4) en zona (F).
- (GB)** Assemble the KIT TOP (2) with the screws (3) in the zone (I), and screws (4) in the zone (F).
- (F)** Monter le KIT TOP (2) à l'aide des vis (3) en zone (I), et des vis (4) en zone (F).
- (D)** Den KIT TOP (2) mit den Schrauben (3) in Zone (I) montieren. Den Schrauben (4) in Zone (F) gemäß.
- (I)** Montare il KIT TOP (2) mediante le viti (3) nella zona (I) e le viti (4) nella zona (F).

5.

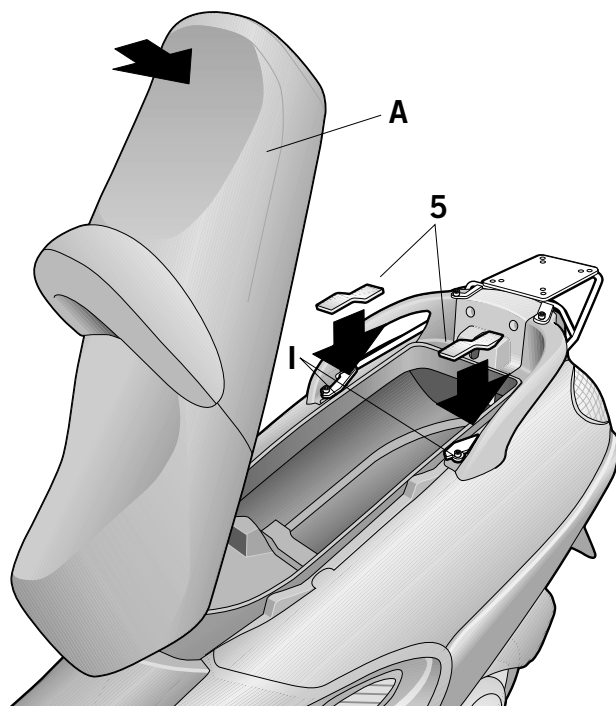

- (E)** Colocar la protección de espuma (5) en zona (I).
Cerrar el asiento (A).
- (GB)** Place the foam protection (5) in the zone (I).
Close the seat (A).
- (F)** Placer la protection en mousse (5) en zone (I).
Refermer la selle (A).
- (D)** Den Schaumschutz (5) in Zone (I) anbauen.
Noch einmal den Sitz montieren (A).
- (I)** Collocare la protezione di schiumatura (5) nella zona (I).
Chiudere il sedile (A).

COMPONENTES / PARTS / COMPOSANTES / EINZELBAUTEILE / COMPONENTI:

| Pos. | Ref. | | Cant. | |
|------|--------|---|-------|---|
| 1 | 260611 |  | 2 | Distanziador ø13 x 68 - Spacer - Entre-toise - Abstandshalter - Distanziatore |
| 2 | 260612 |  | 1 | Kit top |
| 3 | 304061 |  | 2 | Tornillo M6 x 60 DIN 7991 - Screw - Vis - Schraube - Vite |
| 4 | 304153 |  | 2 | Tornillo M6 x 110 DIN 912 - Screw - Vis - Schraube - Vite |
| 5 | 260291 |  | 2 | Adhesivo espumado - Adhesive foam - Adhésif en mousse Anhaftender Schaum - Schiumatura adesiva |